

HondaJet ELITE

Specifications Overview

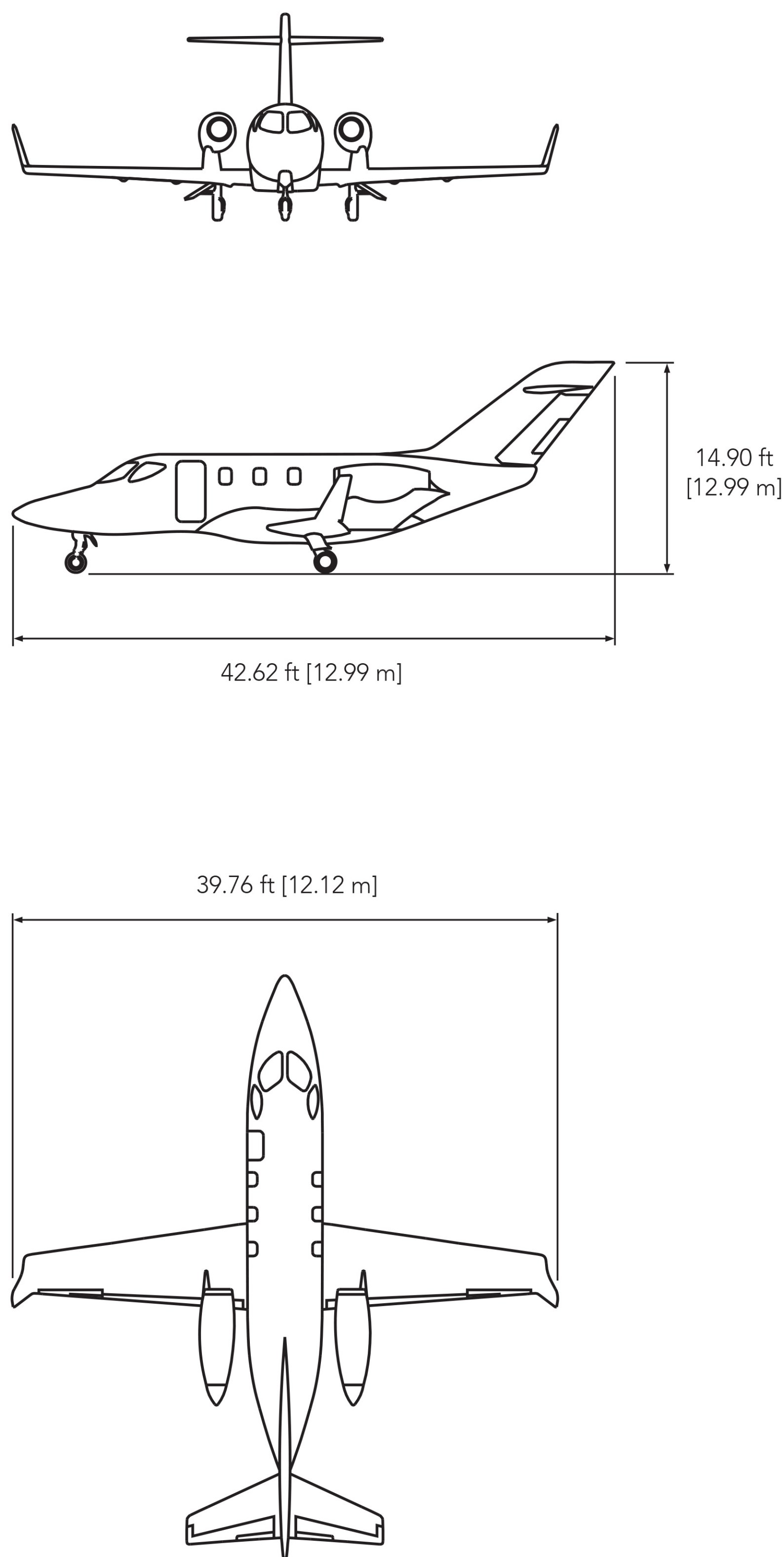

Reimagining flight from the ground up.

Performance

Maximum Cruise Speed @ FL300	422 KTAS	[782 km/h]
Maximum Cruise Altitude	FL430	
Rate of Climb	4,100 ft/min	[1,250 m/min]
NBAA IFR Range (4 occupants)	1,437 nm	[2,661 km]

Engines

Manufacturer / Model	GE Honda / HF120
Output (Uninstalled Thrust)	2,050 lbf x 2 [9.12 kN x 2] Derated from 2,095 lbf/each
Bypass Ratio	2.9

External Dimensions

Length	42.62 ft	[12.99 m]
Wing Span	39.76 ft	[12.12 m]
Height	14.90 ft	[4.54 m]

Interior Cabin Dimensions

Length	17.80 ft	[5.43 m]
Width	5.00 ft	[1.52 m]
Height	4.83 ft	[1.47 m]

Baggage Space

Combined Stowage	66 cubic ft
Within Aft Section	57 cubic ft
Within Nose Section	9 cubic ft

Configuration

Typical Configuration	2 crew + 5 passengers (1 crew + 6 passengers)
-----------------------	--



* NBAA IFR Range (4 occupants): 1,437 nm [2,661 km]